

# МОЩНЫЙ СВЕТОДИОД ARPL-25/31W-LTA-1919-97

## ОСОБЕННОСТИ

- Высокая световая эффективность (>100 лм/Вт)
- Высокий индекс цветопередачи (CRI>97)

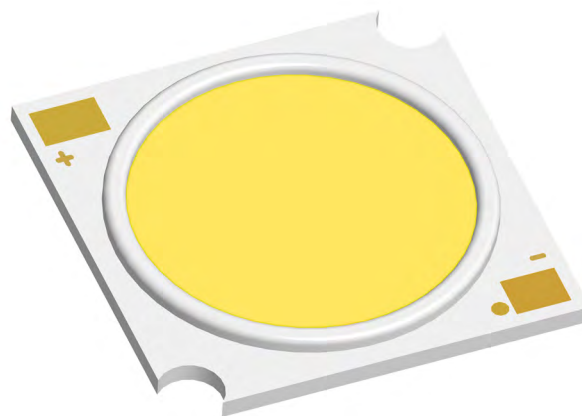

## ПРИМЕНЕНИЕ

- Светодиодные светильники (трековые, даунлайты)

## ГАБАРИТНЫЕ РАЗМЕРЫ

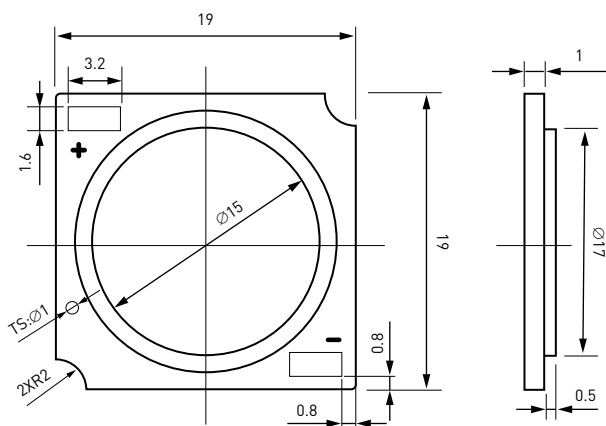

Notes: All dimensions in mm.  
The tolerances unless mentioned are  $\pm 0.3$ , unit=mm.

## LIMIT PARAMETERS

Parameter	Symbol	Min	Max	Unit
Forward Current	$I_F$	/	<b>1840</b>	<b>mA</b>
Forward Voltage	$V_F$	<b>33.6</b>	<b>39.6</b>	<b>V</b>
Operating Temperature	$T_{opr}$	<b>-10</b>	<b>+85</b>	<b>°C</b>
Storage Temperature	$T_{stg}$	<b>-40</b>	<b>+100</b>	<b>°C</b>
Soldering Temperature	$T_{sol}$	/	<b>350</b>	<b>°C</b>
Junction Temperature	$T_j$	/	<b>125</b>	<b>°C</b>
Thermal Resistance	$R_{j-c}$	/	<b>0.57</b>	<b>°C/W</b>
Antistatic Ability	ESD	<b>2000</b>	/	<b>V</b>

The using temperature is less than 85°C; please reduce the using current or contact with us if using temperature is more than 85°C.  
When hand soldering, keep the temperature of iron below less 350°C less than 5 seconds.

## ELECTRO-OPTICAL CHARACTERISTICS

( $I_f = 1200$  mA,  $T_c = 25$  °C)

CCT	CRI, min Ra	R9	Luminous Flux Min	Typ	Efficacy (typ), lm/W	Voltage (typ), V
<b>3000 K</b>	<b>97</b>	<b>70</b>	<b>4290</b>	<b>4515</b>	<b>101</b>	<b>36.5</b>
<b>4000 K</b>	<b>97</b>	<b>70</b>	<b>4440</b>	<b>4665</b>	<b>105</b>	<b>36.5</b>

The tolerance of measurement at our tester is voltage $\pm 5\%$ , luminous flux $\pm 7\%$  and Ra\R9 $\pm 1$ .  
Luminous flux inside the integrating sphere measurements.

Art.	CRI	$I_f$	flux
<b>034738</b>	<b>97</b>	<b>720 mA</b>	<b>2 840 lm</b>
<b>034479</b>	<b>97</b>	<b>720 mA</b>	<b>2 840 lm</b>
<b>034743</b>	<b>97</b>	<b>900 mA</b>	<b>3 500 lm</b>
<b>034742</b>	<b>97</b>	<b>900 mA</b>	<b>4 440 lm</b>

# CHROMATICITY COORDINATE GROUPS

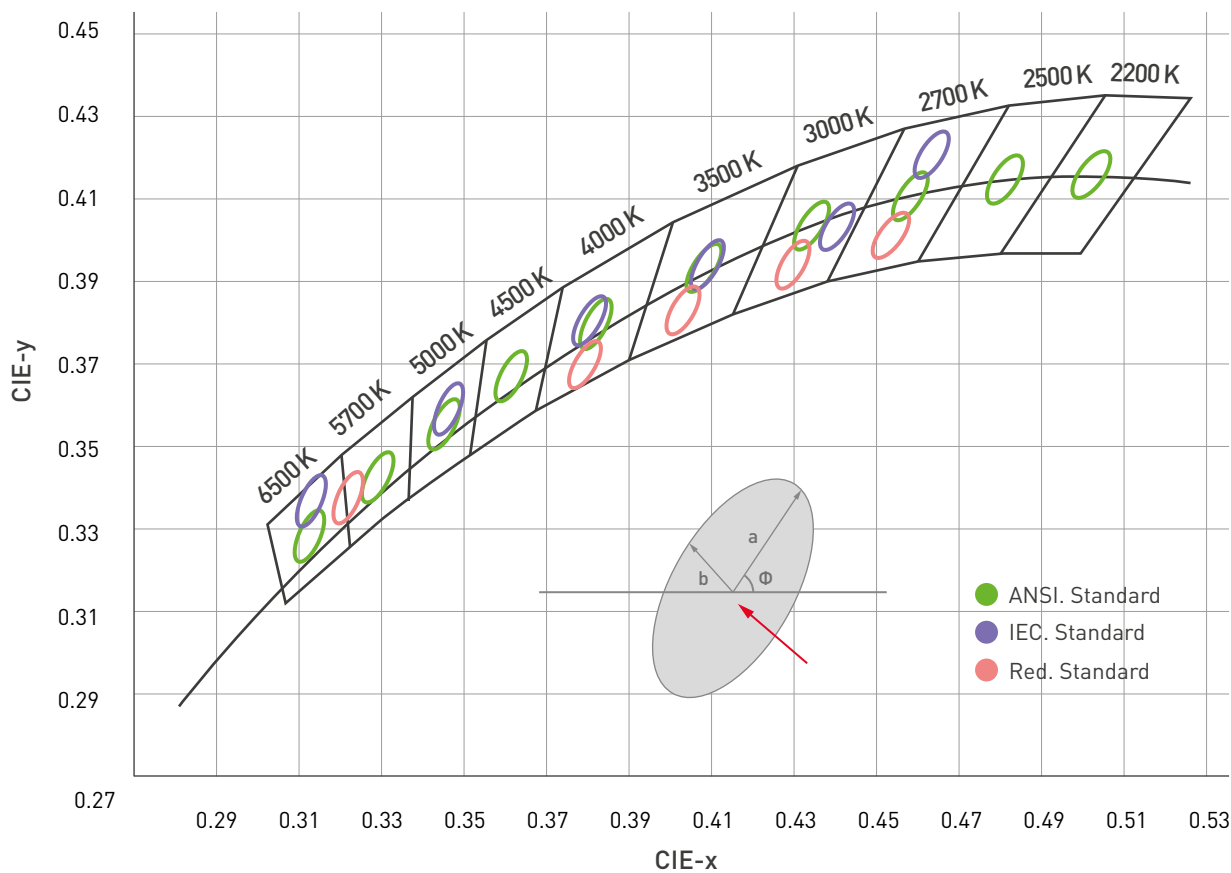

# CHARACTERISTIC CURVES

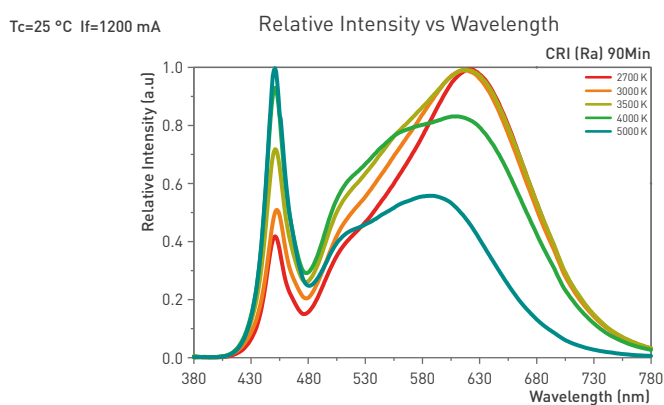
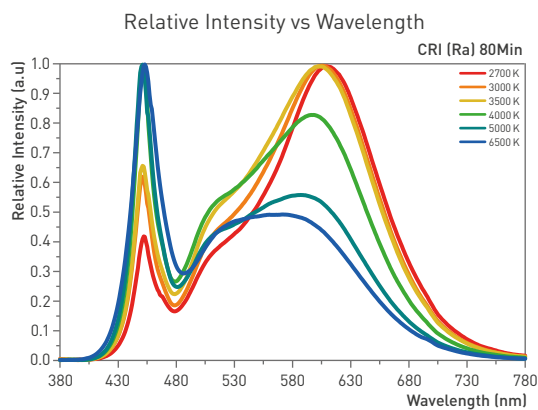
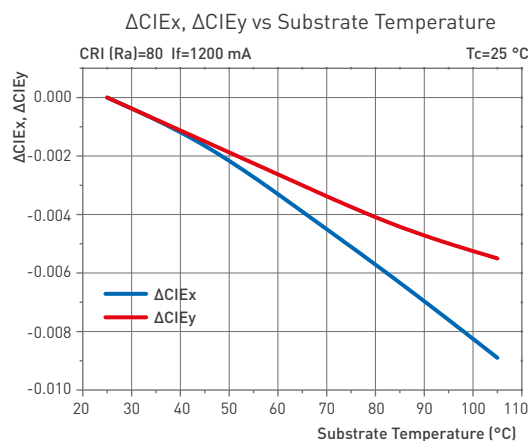
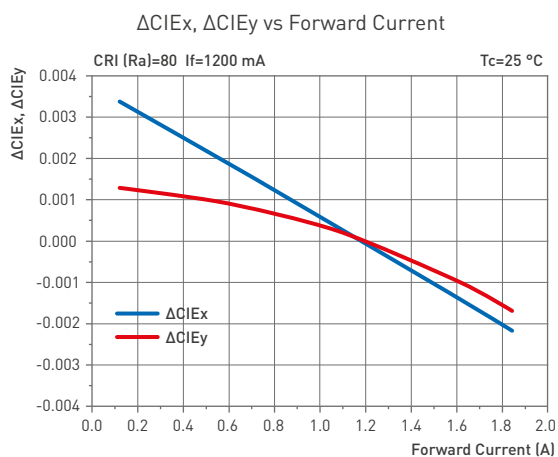
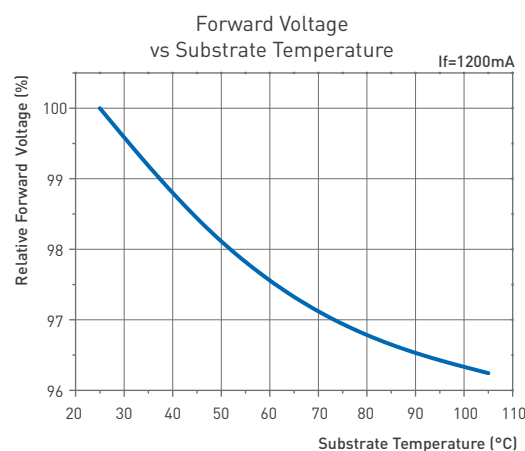
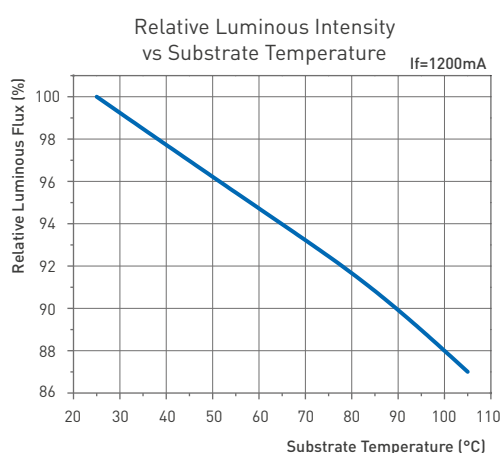
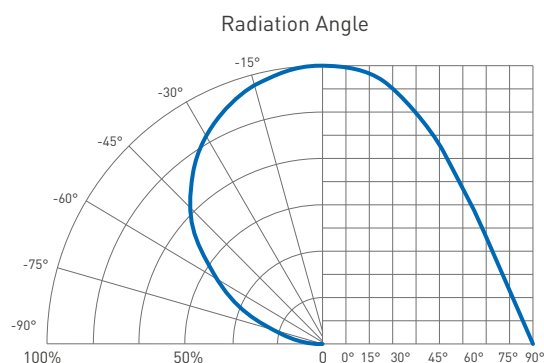
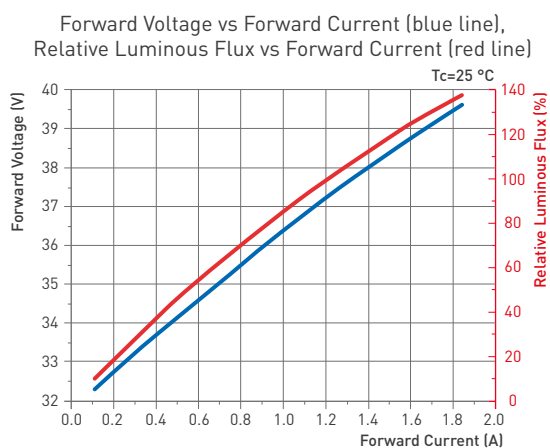

# УПАКОВКА

